

# MTO-1651H Open Frame Solenoids

Plunger Weight  
Total Weight

可動鐵心重量: 78g  
總重量: 507g

Shown Energized  
UNIT 單位: mm

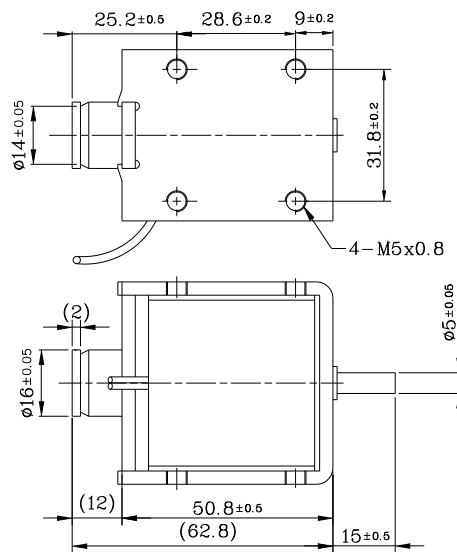
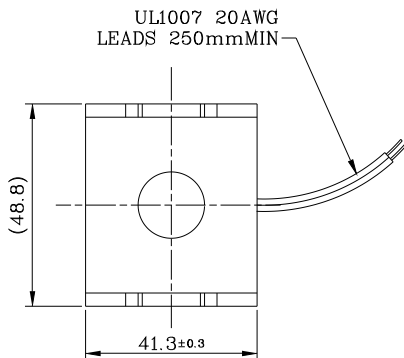
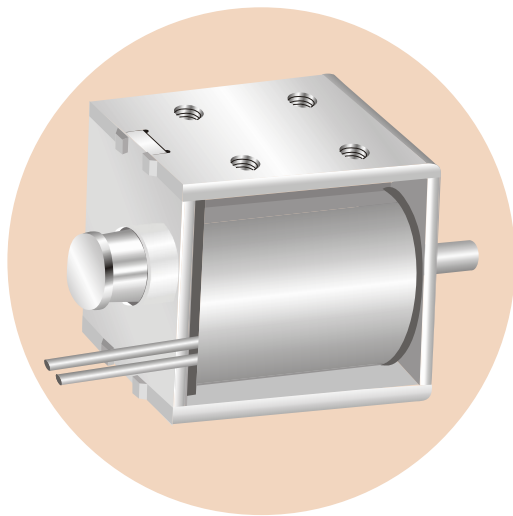

Tooling owned by customer

## COIL DATA 線圈資料

$\text{Duty Cycle (\%)} = \frac{\text{"ON" time}}{\text{"ON" time} + \text{"OFF" time}} \times 100\%$ $\text{作動週期 (\%)} = \frac{\text{ON時間}}{\text{ON時間} + \text{OFF時間}} \times 100\%$			Continuous(100%) 連續(100%)	Or less(50%) 間斷(50%)	Or less(25%) 間斷(25%)	Or less(10%) 間斷(10%)
MAX. "on" time in seconds 最大 ON 時間 (秒)			∞	140	50	9
Watts at 20°C 瓦特數 (w) (在20°C)			6	12	24	60
Ampere-turns at 20°C At值 (在20°C)			952	1349	1904	3015
Type No.	Resistance(20°C) Ω ±10%	No. Turns	Volts DC (電壓)			
型號	阻值(Ω) ±10%	繞線圈數				
MTO-1651HAA	6	952	6	8.5	12	19
	24	1904	12	17	24	38
	96	3808	24	34	48	76
	384	7616	48	68	96	152

行程 吸引力  
STROKE Vs FORCE

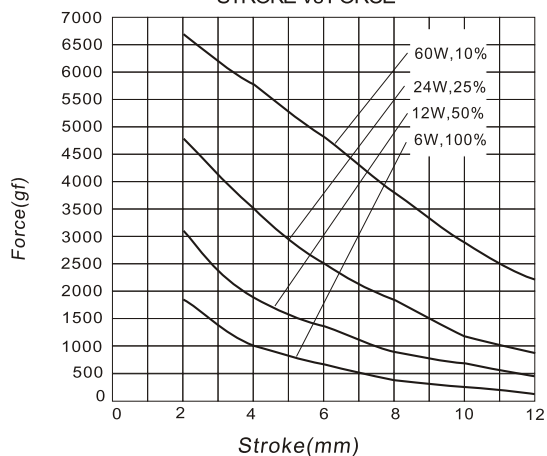

安匝 吸引力  
AMPERE-TURNS Vs FORCE

